

LUCK NOW

Quality Products Since 1968

Manufactured by:
Helm Welding (1983) Limited

Vertical TMR Mixer Feeders

“Twin Screw”

Standard Features

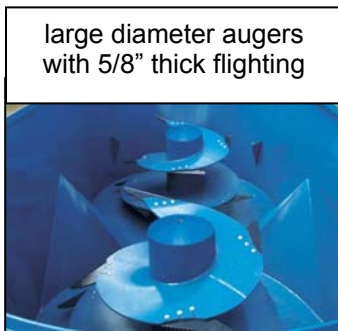

Standard Features

- Adjustable tongue for ease of hook on various draw bar heights
- Door cylinder equipped with relief valve protection
- Planetary drive system with easily accessible service and maintenance lubricating
- Tungsten coated knives
- 540 rpm (2250 model only)
- 1000 rpm (2260, 2270 & 2290 models)
- 2 speed gearbox standard on 2290 model
- All twin screw vertical mixers come complete with a four point scale system including a basic read up, read down electronic indicator

Options



Hydraulic raise and lower discharge conveyor extensions

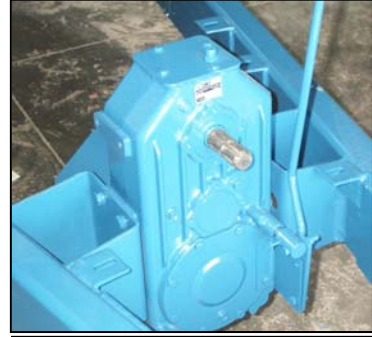

2-speed gearbox for better mixing power (2260 & 2270 only)



magnet kit available for slide chute or unloading conveyor



Chain overflow kit to retain lighter mixes in tub



9" rubber extension for larger capacity mixes

- Upgrade to various electronic scale indicators and accessories
- Special conveyor lengths
- knife option – carbide tip

Twin Screw Specification Table

	<u>MODEL</u> 2250	<u>MODEL</u> 2260	<u>MODEL</u> 2270	<u>MODEL</u> 2290	<u>MODEL</u> 2295 (Single Axle)	<u>MODEL</u> 2295 (Tandem Axle)
A - Overall Height	97	106	113	114	115	130
B - Tub Length	204	228	234	252	263	263
C - Overall Length	253	287	294	310	315	315
D - Overall Transport Width - Bi-direction conv.	102	102	102	104	116	116
- 36" Conveyor Extension	110	110	110	110	116	116
E - Tub Width	73	85	87	96	102	102
F - Tread Width	90	102	102	104	116	116
G - 36" Conveyor Ext - lowest position reach	24	24	24	24	24	29
H - 36" Conveyor Ext - min. unloading height	36	36	36	36	36	41
- max. unloading height	51	51	51	51	51	56
I - Bi-direction Cross Conv. - max. unloading height	25	25	25	25	25	30
Scale System	4 - Point	4 - Point	4 - Point	4 - Point	4 - Point	4 - Point
Tires (Size subject to availability)	33 X 15.5- 16.5 (2)	44 X 18 (2)	46 X 16 (2)	46 X 16 (2)	49 X 17 (2)	44 X 16 (4)
Number of Augers	2	2	2	2	2	2
Tungsten Coated Knives (quantity)	6	7	7	8	8	8
Auger Flighting (thickness)	5/8	5/8	5/8	5/8	5/8	5/8
Floor Thickness (excluding 5/8" support plates)	5/8	3/4	3/4	3/4	3/4	3/4
Hopper Wall (thickness)	1/4	1/4	1/4	1/4	1/4	1/4
Door Opening (width x height)	44 x 24	44 x 30	44 x 30	44 x 30	44 x 30	44 x 30
PTO	540 rpm	1000 rpm	1000 rpm	1000 rpm	1000 rpm	1000 rpm
Weight c/w cross conveyor & ext. (approx. lbs.)	9,880	14, 000	15, 775	16, 325	17,550	19,100
Cubic Ft. Level Capacity	425	575	670	805	950	950
Cubic Ft. Level Capacity (with 9" rubber extension)	490	650	745	900	1100	1100

Unless otherwise indicated, all dimensions are in inches with standard equipment installed.

Specifications subject to change without notice.

Certain features shown may be optional.

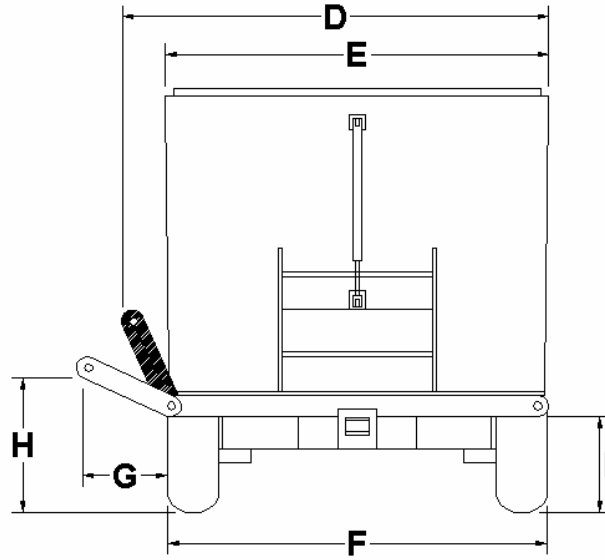

Twin Screw Vertical Front View

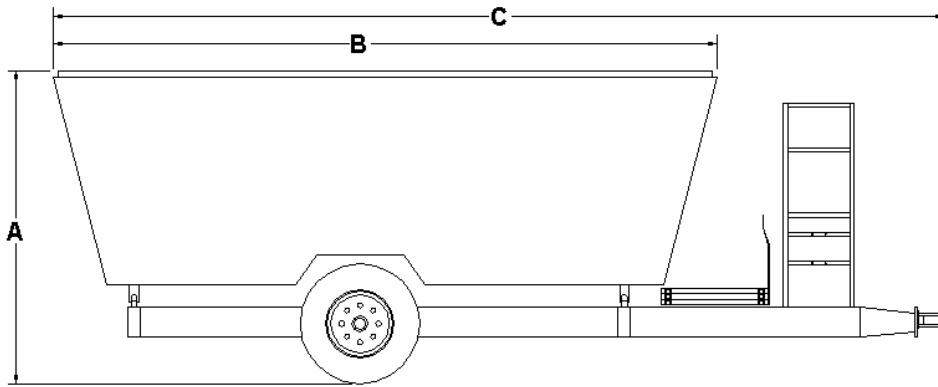

Twin Screw Vertical Side View